

## 4T65E 1997-Up

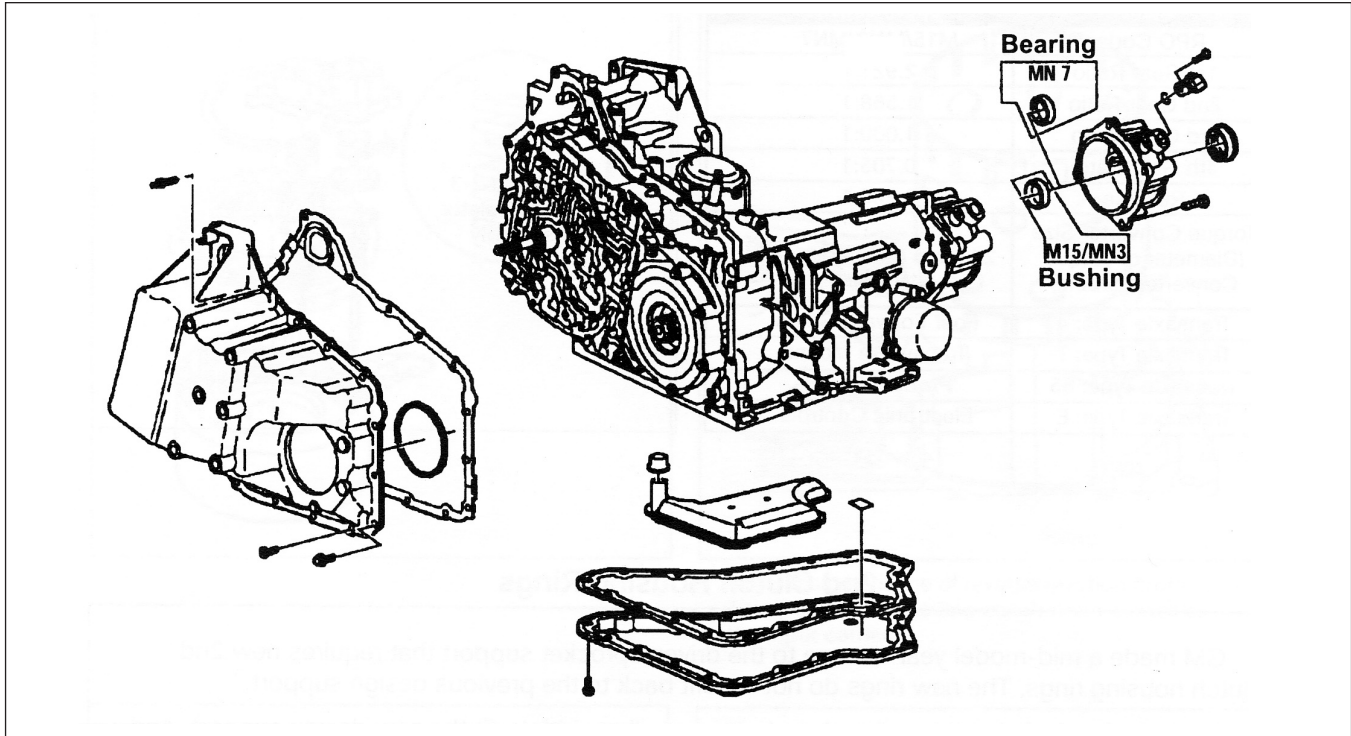

### Power Flow Chart

	Sol. A	Sol. B	Input Clutch	Second Clutch	Third Clutch	Fourth Clutch	Fwd. Band	D-2 Band	Rev. Band	Input Sprag	1-2 Roller	3RD Sprag
Park/Neutral			On*							On*		
Reverse	On	On	On						On	Hold		
D4/1st	On	On	On				On			Hold	Hold	
D4/2nd	Off	On	On*	On			On			O/R	Hold	
D4/3rd	Off	Off		On	On		On				O/R	Hold
D4/4th	On	Off		On	On*	On	On				O/R	O/R
D3/1st	On	On	On		On		On	On		Hold	Hold	Hold
D3/2nd	Off	On	On*	On			On	On		O/R	Hold	
D3/3rd	Off	Off	On	On	On		On				O/R	Hold
D2/1st	On	On	On		On		On	On		Hold	Hold	Hold
D2/2nd	Off	On	On	On			On	On		O/R	Hold	
Lo/1st	On	On	On		On		On	On		Hold	Hold	Hold

\*Applied But Not Effective

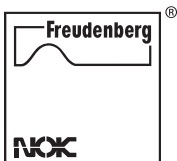

A Division of Freudenberg-NOK

### Transaxle General Specifications

Name	Specification
RPO Codes	M15/MN3/MN7
1st Gear Ratio	2.921:1
2nd Gear Ratio	1.568:1
3rd Gear Ratio	1.000:1
4th Gear Ratio	0.705:1
Reverse	2.385:1
Torque Converter Size (Diameter of Torque Converter Turbine)	245 mm (M15) 258 mm (MN3/MN7)
Transaxle Type: 4	Four Forward Gears
Transaxle Type: T	Transverse Mount
Transaxle Type: 65	Product Series
Transaxle Type: E	Electronic Controls

### Accumulator

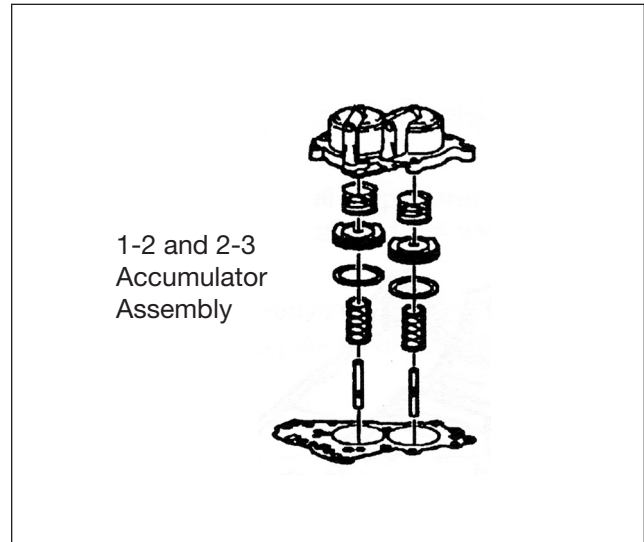

### 2nd Clutch Housing Rings

GM made a mid-model year change to the driven sprocket support that requires new 2nd clutch housing rings. The new rings do not retrofit back to the previous design support.

The new design 2nd clutch housing rings have a smaller width to fit the new design support, and one larger locking tab to prevent it from accidentally being installed on the previous design sprocket support.

The new support and rings no longer require the rubber quad expanders that were required in the previous design.

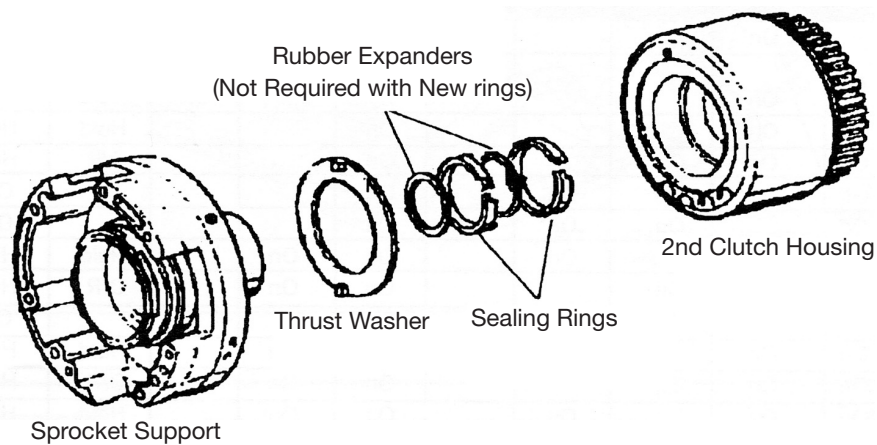

### 2nd Clutch Assembly

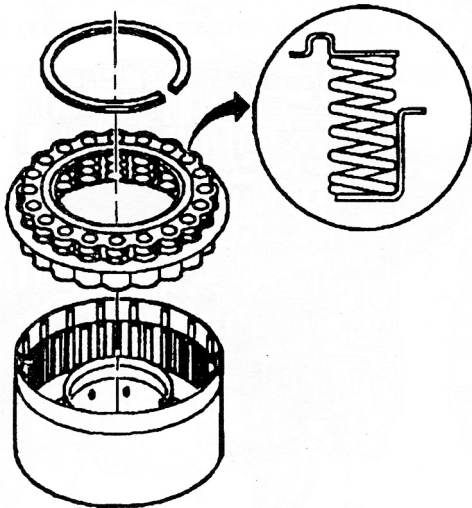

### Reverse Reaction Drum

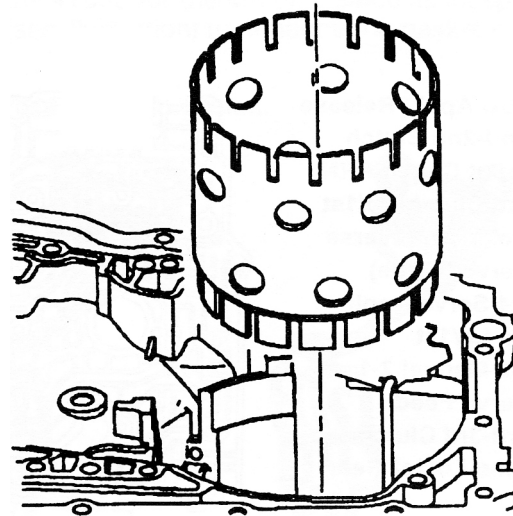

Note design change of reverse reaction drum. This also affects the 2nd clutch drum as well as the input carrier.

### Input and 3rd Clutch Sprag Rotation

Must freewheel in direction of arrows and hold in opposite direction.

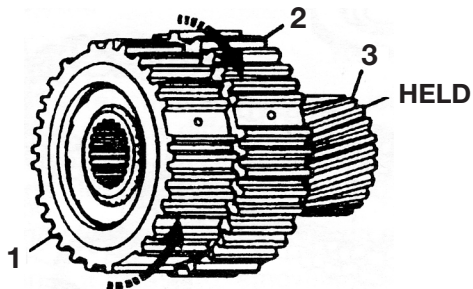

- 1 - 3rd Sprag Clutch Outer Race
- 2 - Input Sprag Outer Race
- 3 - Input Sun Gear

### 1-2 Roller Clutch Rotation

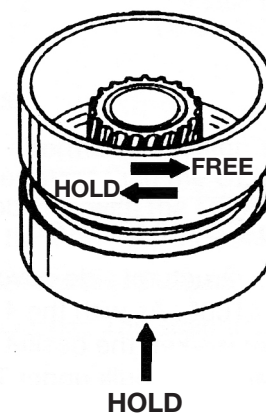

Must rotate counterclockwise and hold clockwise.

### Checkball Locations

- 1) TCC Apply-Release
- 2) 2nd-2nd Clutch
- 3) Input Clutch PRN
- 4) 3rd Clutch-Lo/1st
- 5) Reverse-Reverse Servo (Large)
- 6) D4-Servo Apply
- 7) Lo/Lo/1st
- 8) D2-Manual 2-1 Servo Feed
- 9) 3rd-3rd Clutch
- 10) Line-Lo/1st Gear

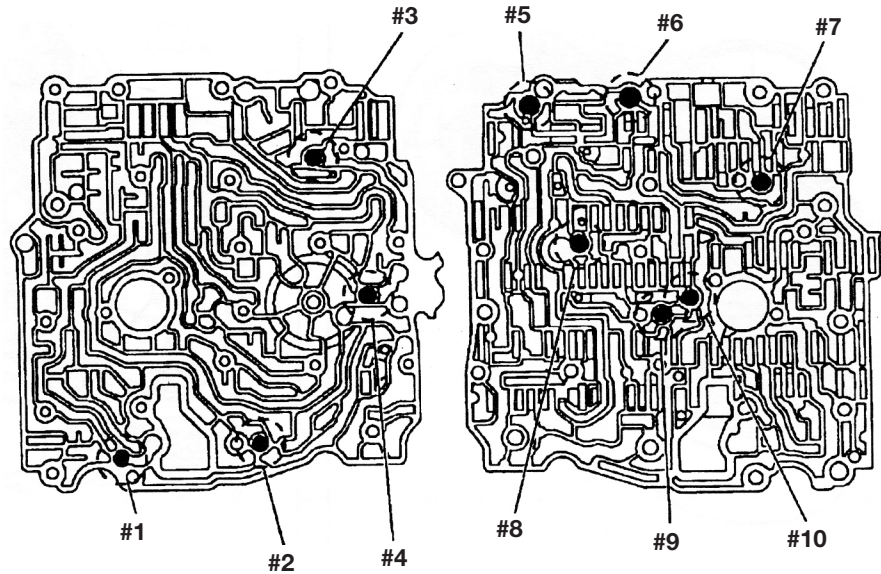

**Note:** Sprocket teeth and chain lugs are offset for noise reduction.

### Side Cover Gasket

The 4T65E uses a structural side cover similar to the one in the 4T60E. As with the 4T60E molded side cover gasket, the gasket in the 4T65E is only available in bulk under TransTec® #B36455

### Drive and Driven Sprocket Components

Speed Sensor  
Reluctor Wheel

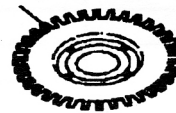

Drive Chain

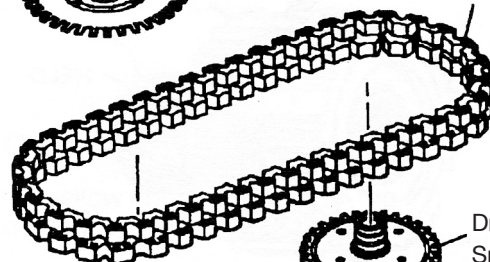

Driven Sprocket Support

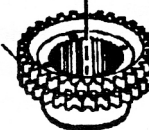

Drive Sprocket



**Application: General Motors 4T65E 1997-Up**

**Subject: Upper Channel Plate Gasket**

General Motors has changed the upper channel gasket for the 4T65E for the 4th time since its inception. In the latest revisions, GM has added a material bridge (see illustration) to enhance the gasket's strength in order to reduce the possibility of gasket blowout.

**Note:** GM did not change the OEM part (24220217) for the latest design.

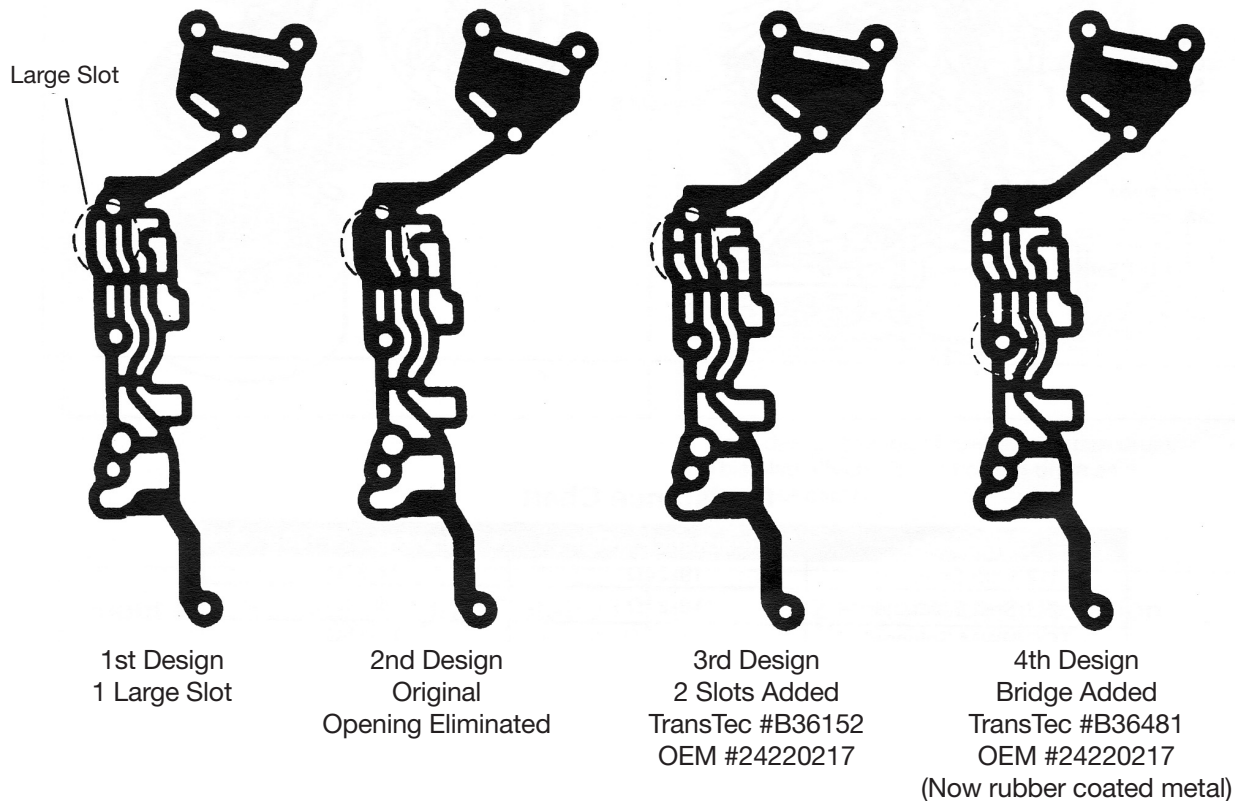

**Rubber Accumulator Seals**

The lathe (square) cut accumulator seals in this kit are TransTec® brand aftermarket design seals. The dimensions are slightly different, and the material is more abrasion-resistant than the OEM seals. The design of these seals was improved because of occasional wear problems with the OEM seals. The transmissions most affected are the 4T60/E and AXOD, due in part to the design of these accumulators.

*The following steps should be taken on every overhaul to prevent premature seal wear:*

- 1) Always rinse the case to remove any soap film left from the parts washer. The soap acts as an abrasive that causes seal wear.
- 2) Always resurface the accumulator bores with Scotch Brite®. A smooth bore has no place to hold oil for lubrication. Without lubrication, seals wear out prematurely. (Scotch Brite is available through parts stores, body shop suppliers, or tool distributors).
- 3) Always check the accumulator piston-to-pin fit, especially on the aluminum pistons in the 4T60/E. Any wear here will cause the piston to wobble in the bore and wear out the seal.

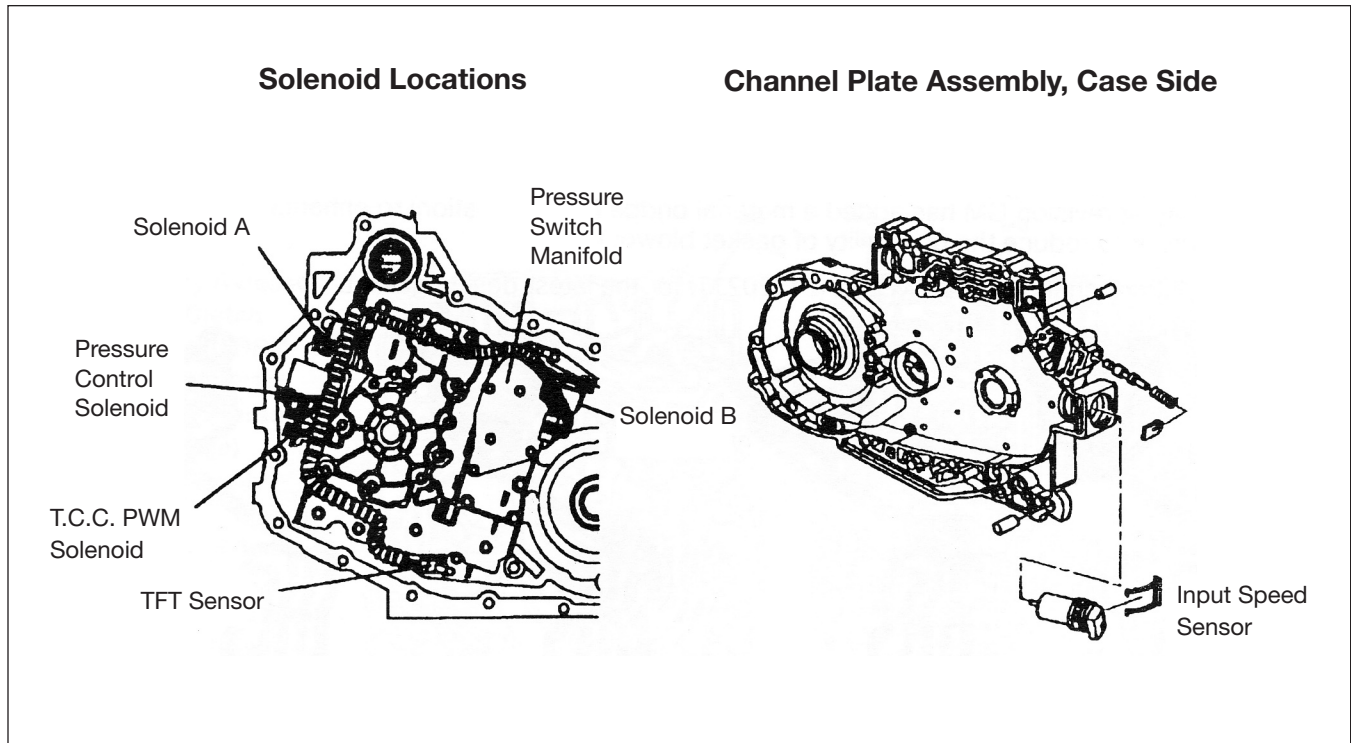

### Resistance Chart

Component	Resistance @ 68°F	Resistance @ 190°F
1-2 Shift Solenoid	19-24Ω	24-31Ω
2-3 Shift Solenoid	19-24Ω	34-31Ω
TCC/PWM Solenoid	10-12Ω	13-15Ω
EPC Solenoid	3-5Ω	5-6Ω
Input Speed Sensor	893-1127Ω	1132-1428Ω
TFT Sensor	3164-3867Ω	225-285Ω
Output Speed Sensor	981-1864Ω	

### Converter Seal: RPO Code M15

In order to offer choices to builders, Corteco offers the yellow converter seal for the 4T65E in bulk sales for those who prefer it. This seal, TransTec® #B37075 (OEM #24204772), is specific to the 1997-up 4T65E transaxle with a "M15" RPO code.

This seal has the same bore and shaft dimensions as the more common converter seal used in 4T65E units with RPO codes MN3 and MN7 (and also in the 3T40 and 4T60/E). The more common seal is included in this kit, and the new seal is available in bulk form from authorized TransTec® brand distributors.

### Input Clutch Inner Lip Seal: Short Lip Design Changed to Long Lip

GM has used a “short” lip design seal for the 4T60/E input clutch inner location since approximately 1991. The short lip was used with the introduction of the “E” model, and through the end of 4T60 production in 1993. It was also used in the 4T65E since 1997. The short lip design seal was used for ease of assembly at the factory, as well as its cost savings over a molded, “long” lip seal.

It has been shown, however, that in this application a long lip design seal will outperform the current O.E. short lip type. Using a long lip seal has also been a rebuild recommendation from various tech services.

We have, therefore, switched the current input inner short lip seal to a long lip seal. The long lip seals are in all TransTec® brand gasket/seal and overhaul kits with date codes of F99 and later.

#### Input Clutch Inner Lip Seal

Design	TransTec® #	OEM #
Previous, Short Lip	28230	8651443
New, long Lip	28328	8649836

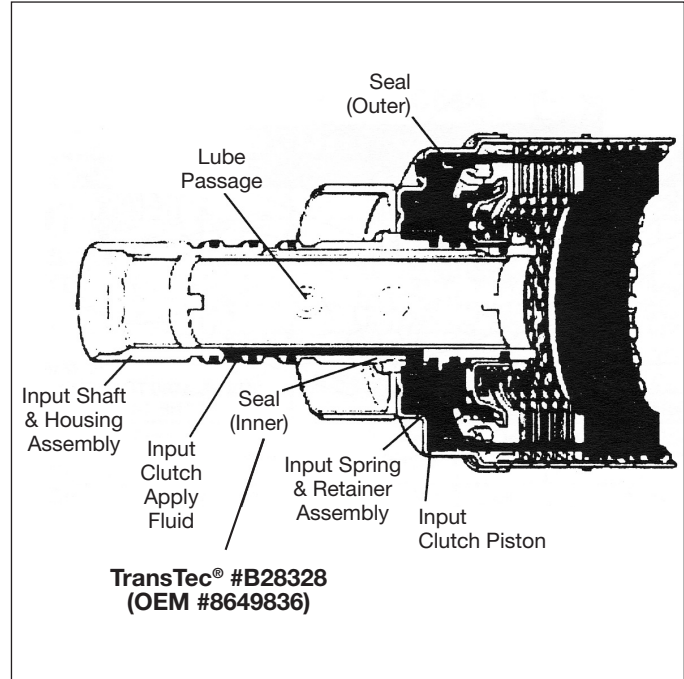

### Short Lip Seals Replaced by Long Lip Seals

GM has used a “short” lip design seal for the 4T60/E and 4T65E reverse servo piston since 1985. The short lip was used in the 4T60 through the end of production in 1993, all of 4T60E production, and in current 4T65E production. The short lip design seal was used for ease of assembly at the factory, as well as its cost savings over a molded, “long” lip seal.

It has been shown in this application, however, that a long lip design seal will outperform the current O.E. short lip type. Using a long lip seal also has been a rebuild recommendation from various tech services, as well as through bench testing and field testing.

Therefore, we have switched to a long lip design seal for the reverse servo in the 4T60, 4T60E and 4T65E, and the forward servo in the 4T60E and 4T65E. The long lip seals are in all TransTec® brand gasket/seal and overhaul kits with a date code of B03 and later.

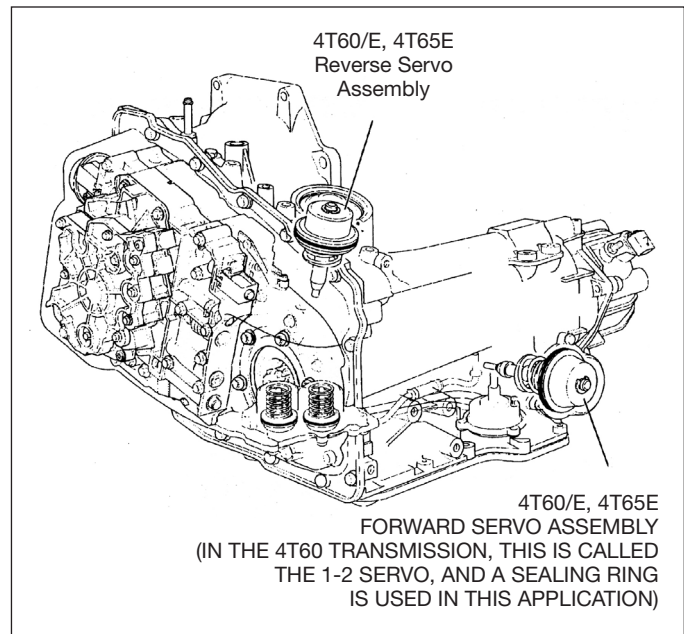

**Application: 4T65E with Manual Shift Option (RPO code KB7)**

**Subject: Valve Body Gaskets**

In 2004, GM offered the 4T65E with a manual shift option under a regular production order (RPO) code of KB7). The Pontiac Grand Prix was the first to offer this option to consumers with other applications to follow.

The valve body gaskets in sub kit 4781 are to be

used on 4T65E applications that have the manual shift option. The valve body gaskets that are loose in the main kit are for units that do not have the manual shift option.

**Application: General Motors 4T65E**

**Subject: Electronic Pressure Control Solenoid (EPC) O-rings**

In 2003, General Motors went from a Holly designed EPC solenoid to a Bosch design solenoid. The new Bosch solenoid required thicker o-rings than the previous Holly solenoid. All 4T65E TransTec® brand kits contain both sets of o-rings.

Please see illustration for solenoid information.

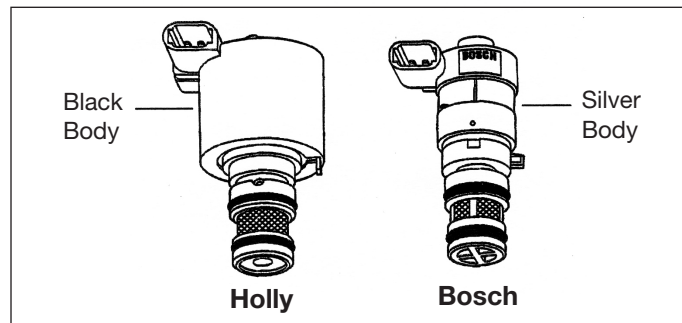

**Application: 4T65E**

**Subject: Molded Pan Gasket**

Since its inception in 1997, GM has used a molded rubber pan gasket on the 4T65E. The original molded gasket, as well as the pan and case, required 8mm bolts. In mid-year of 1998, GM changed the bolts from 8mm to a 6mm shank, along with the case and pan to accommodate the new bolts.

Since the number of later models requiring the 6mm bolt pan gasket is far greater than the previous 8mm design, all kits with a date code of A06 and later contain the 6mm gasket. The early 8mm molded pan gasket will still be available for bulk sales.

Part #B32542 covers 1997 to early 1998 with 8mm bolt holes and part #B33212 covers early 1998-up with 6mm bolt holes.

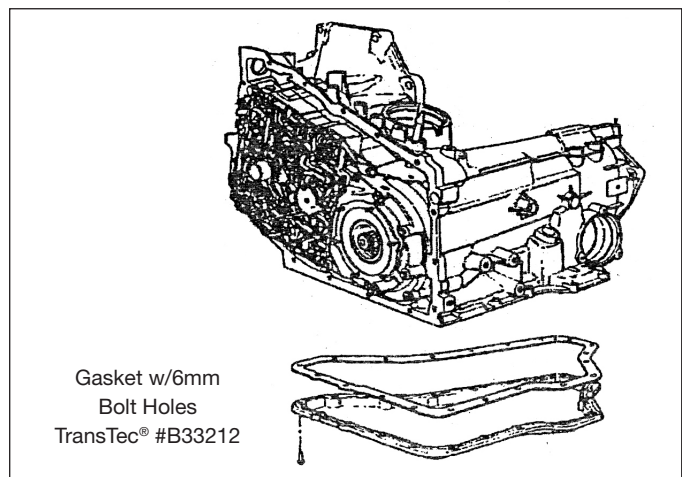

A Division of Freudenberg-NOK